

musikelectronic geithain



Studio
Monitor Loudspeaker
MO-2



musikelectronic geithain



The Reference Class - Active Studio-Monitors made by musikelectronic geithain

Our loudspeaker

From a compact two-way monitor up to large loudspeaker-systems - we provide you with the best solutions for all kinds of professional use. The RL series' studio-monitors are the result of consequent development that needed many years and pursued only one aim: the highest degree of precise sound without any coloration regardless of genres. Hearing and measuring are the basis of our work. We build on profound musical comprehension and the knowledge of unalterable physical laws - not on magic tricks, new fashioned ideas nor marketing-strategies.

You have to do it yourself!

We produce loudspeaker in accordance to our conviction. That is why we develop and construct all monitors ourselves - from A to Z, from the electronics of the amplifier to the voice coil of the transducer. A product, which components all come from our own manufacturing, has noticeable advantages for you as a professional customer. We are independent of third parties products and build our components just the way we require them - this proceeding can't be beaten in quality by mass-production. This strategy also leads to high continuity and a fixed (stable) value of our product range as well as it ensures that

replacement parts will be available for long-term. We believe that this is the only way to create a product which is worth your investment and satisfies your professional needs for many years.

Active and Coaxial

Active multi-way technique with internal crossovers, power amplifier, and our special coaxial arranged transducers are the basis of all professional monitors of our RL series. As a result of this technology our speaker reveal a great depth and precise focus and low harmonic distortion. We used physiological effects of hearing to optimize the power concentration and directivity of sound. This degree of accuracy of sound is unmatched by any other.

Made from one piece

All RL-loudspeaker from the compact RL 906 to the RL 900 A are tonal compatible with each other. Therefore it is your choice where you prefer to work; even within the same production you are independent from the studio environment. No matter if you work in a broadcast van or in a studio - the loudspeaker will not differ in sound, but only in their low-frequency cutoff and the maximum acoustic output.

Studio Monitor Loudspeaker MO-2

The loudspeaker of the type MO-2 is a compact studio monitor of our MO series. It is qualified for the use in near-field and middle-field applications as well as in outside broadcasting vans. With multichannel application we recommend the supplement by one of our active bass loudspeakers, BASIS 1...4. Because of the construction in an active coaxial two-way technology we can ensure sound colour compatibility to our studio control monitor loudspeakers. Moreover, by that constructive measure we can achieve high naturalness and homogeneity of the irradiated sound event. Also with regard to the localisation definition and the feasibly minimum imaging of phantom sound sources the MO-2 is seamless matched to all the loudspeakers of the RL and MO series. The directivity index was determined in such a manner that an operation is feasible up to 1m minimum basis width.

The loudspeaker unit is supplied with a 160 mm cone low-frequency driver and a 25 mm high-frequency dome driver

arranged coaxially. They are powered by separate MOSFET power amplifiers with an active crossover and electronic protection circuit in the back part of the cabinet. The MO-2 contains symmetric XLR input with calibrated input level adjustment.

According to the position of the monitor box the amplitude/frequency curve can be well matched in the low- and in the high-frequency range as well as in the region about 300 Hz by means of the controls on the back side.

The status of operation and also the status when the maximum level is overridden will be signaled by a two-coloured LED. The loudspeaker is magnetically shielded for compensating stray fields.

The design of the box is finished in MDF with true veneer. Various special stands and holds are available as optional extras. The corresponding appliances are integrated in the case.

Specifications

General	active two-way monitor for use in medium audio-, video production studios
Maximum SPL from 100 Hz ... 6 kHz	108 dB...112 dB/ r =1m
Bandwidth	46 Hz...20 kHz \pm 3 dB
Calibration: Acoustic output level / $P_E = -14$ dBu	83 dB / r =1m
Directivity index from 200 Hz...10kHz	increasing from 1 to 9.5 dB
Inherent noise sound level	< 7dB(A) / r =1m
Total harmonic distortion / measured at 96 dB, r =1m, from 80 Hz...10 kHz	<-45 dB
Nominal input level	+6 dBu adjustable
Input impedance	> 10 kOhm / symmetrically
Nominal output power of the MOSFET-amplifier LF HF	80 Watt / 4 Ohm (100 W peak) 80 Watt / 4 Ohm (100 W peak)
Electronic crossover frequencies	2.6 kHz
Operation and clipping indicator	LED on front side
Input connector	XLR 3F
Loudspeaker systems Woofers Tweeter	160 mm cone 25 mm dome
Power requirements	Europe 230 Volt (\pm 10%), AC, 50 Hz USA & Canada 115 Volt (\pm 10%), AC, 60 Hz Japan 100 Volt (\pm 10%), AC, 60 Hz
Power consumption	max. 100 Watt at full load
Temperature requirements for use for storage Humidity	+15°C to +35°C -25°C to +45°C 45 - 75 %
Dimensions (H x W x D) [mm] [inches]	398 x 254 x 245 15.66 x 10.00 x 9.64
Weight	11 kg 24 lb
Design of the Cabinet	MDF wood, black veneer, different colors optional
Magnetic shield	optional

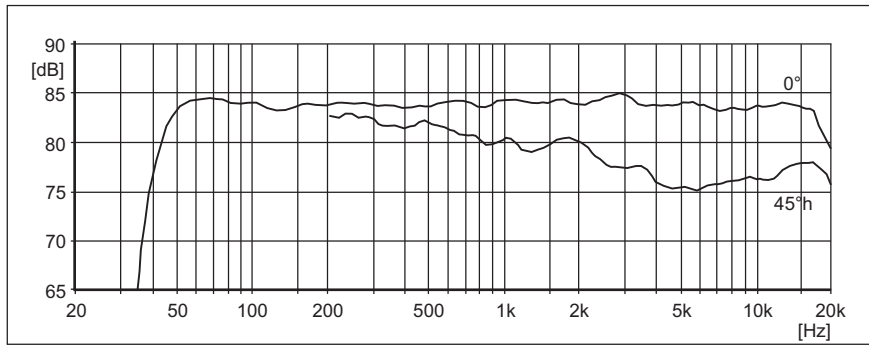

Free field frequency response

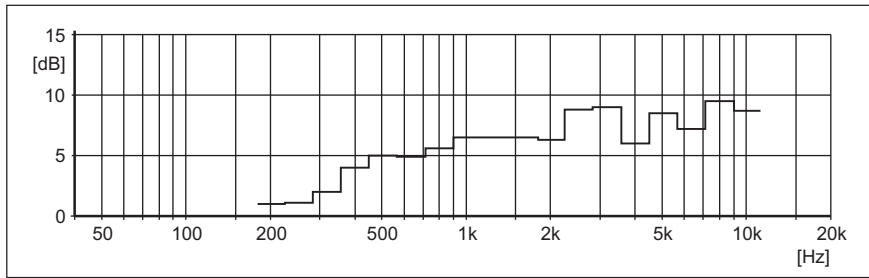

Directivity index

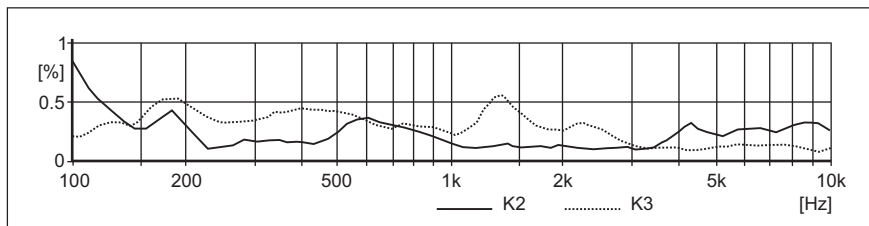

Total harmonic distortion $P_A = 96$ dB

accessories

floor bracket stand:

top edge box:

- 1156 mm
- 1386 mm
- 1516 mm
- 1656 mm

wall holder:

- 25° turning; inclining

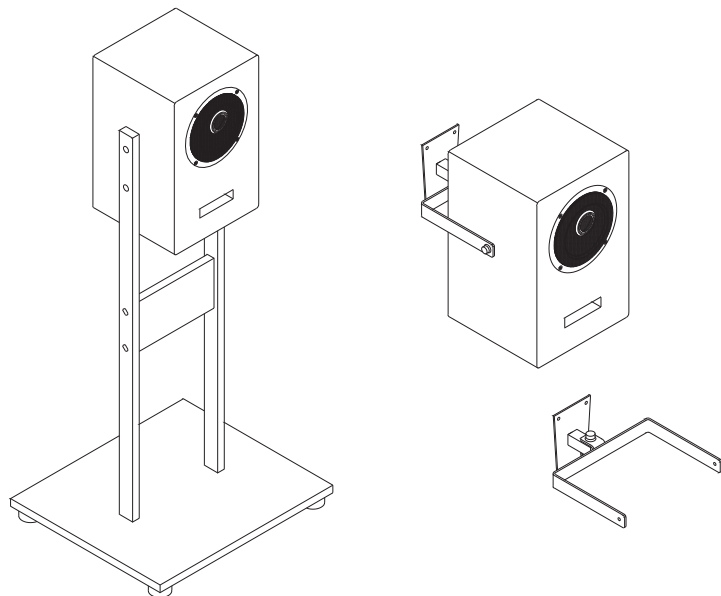

musikelectronic geithain gmbh

studio techniques - sound reinforcement systems

Nikolaistrasse 7

Tel: (+49) 34341 3110

04643 Geithain / Germany

Fax: (+49) 34341 31144

www.me-geithain.de

e-mail: info@me-geithain.de